

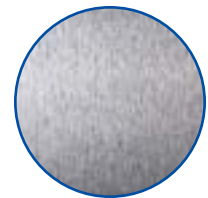

EXL HVLP Gravity Feed Spray Gun

EXL HVLP Gravity Feed Spray Gun

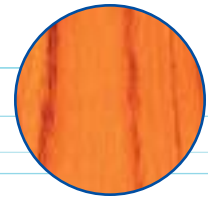
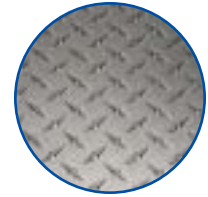

- Advanced technology for the professional painter
- Precision engineered patented #2000 air cap – Meets exacting performance demands, producing an extremely fine finish with all materials. Developed in conjunction with top American and European paint companies to spray the latest materials
- Large spray pattern for fast coverage
- Even distribution of materials for no mottling or striping – Excellent color matching capabilities
- Optimum atomization for clearcoats and single stages – Produces a high gloss finish and minimizes orange peel. Excellent fluid control for applying more film build with fewer passes
- Lightweight and comfortable – Classic DeVilbiss fit and feel
- Economical servicing – Air cap, fluid tips and needles are fully interchangeable and available separately
- Highly efficient HVLP design – Complies with environmental regulation requiring high volume, low pressure. Saves material. Very little overspray
- Low air pressure and volume requirements – (GTI-5033-2000) Air Cap Test Kit (Order separately) Provides consistent setup and regulatory proof of air cap pressure
- Stainless steel fluid tip, needle and fluid inlet adapter
- Less time spent on refills – True 1-Liter aluminum cup with disposable push-on lid
- Quick clean up and upside down spraying (no cup leaks) – with E-Z Liner™ disposable cup liners

EXL HVLP Spray Gun (EXL-620G) includes:

1-Liter aluminum cup (GFC-502) with push-on lid

Air cap cleaning kit, spray lube, fluid filter, gun hook, E-Z Liner™ disposable cup liners (OMX-70-K48)

EXL HVLP Gravity Feed Spray Gun

Technical Specifications:

Model No.	Fluid Tip (mm)	Inlet Air Pressure	Applications
EXL-620G-15	1.5	20-25 psi 25-30 psi	Base Coats Low solids clear coats single stages
EXL-620G-18	1.8	20-25 psi 25-30 psi	High solids and single stages
EXL-620G-22	2.2	20-25 psi 25-30 psi	High solids and single stages

Specifications:

30 psi inlet pressure delivers 10 psi air cap pressure and 16 cfm air volume

Refer to Service Bulletin: SB-2-202

EXL HVLP Gravity Feed Spray Gun

(EXL-620G) HVLP Gravity Feed

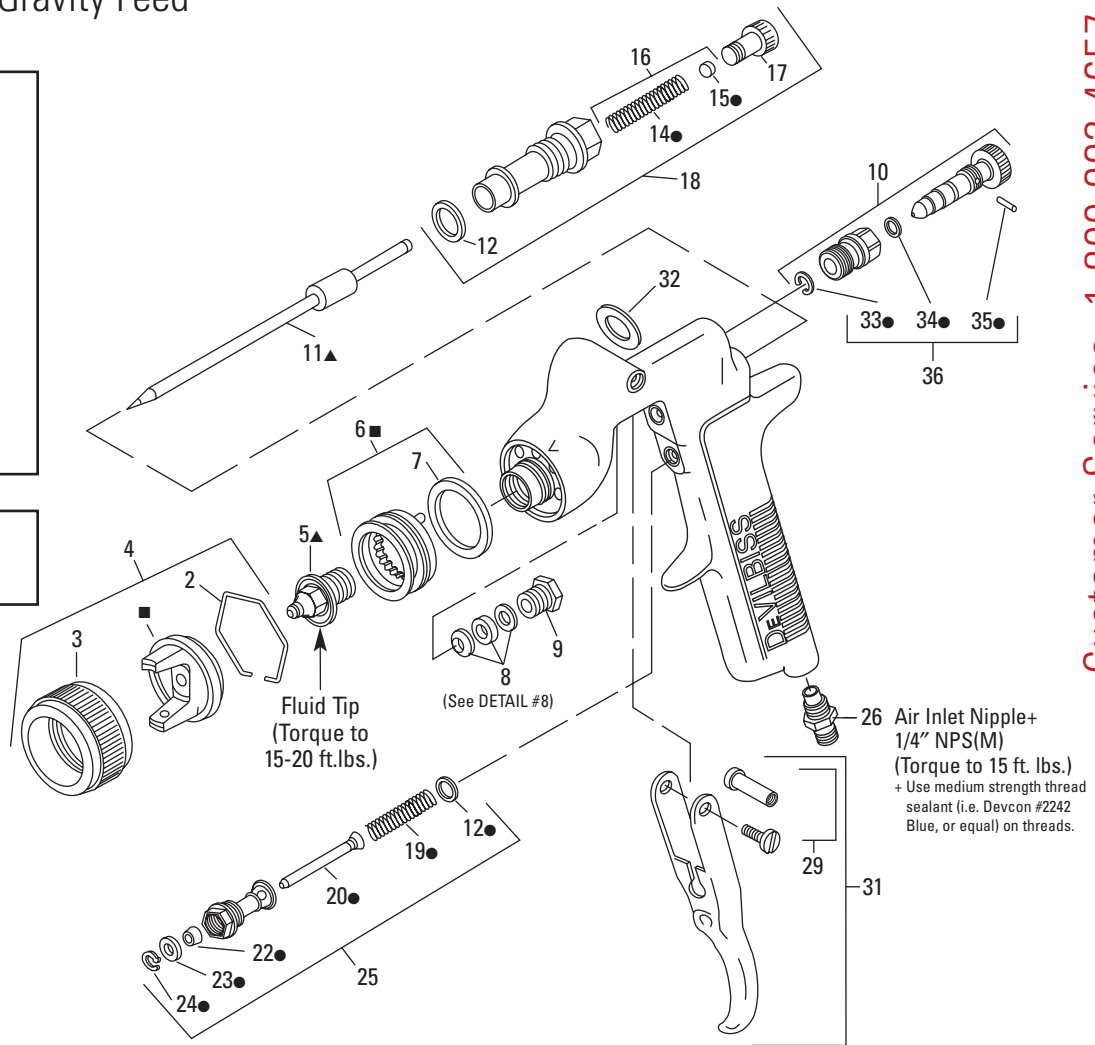
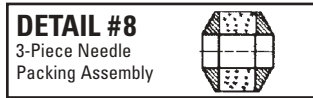
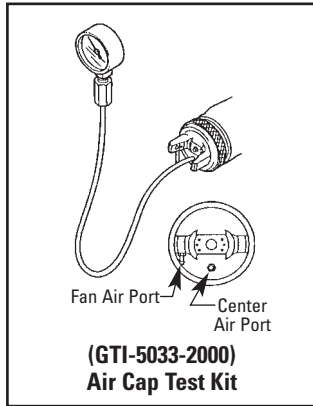

Customer Service 1.800.992.4657

Ref. No.	Model No.	Description	Ind. Parts Required
2	JGA-156-K10	Spring Clip (Kit of 10)	1
3	GTI-3	Air Cap Retaining Ring	1
4	GTI-407-2000	Air Cap (#2000) and Retaining Ring	1
5	See Chart 1	Fluid Tip	1
*6	GTI-425	Baffle Assembly	1
7	GTI-33-K5	Baffle Seal (Kit of 5)	1
*8	JGA-4035-K5	Packing (Kit of 5)	1
9	34411-122-K10	Packing Nut	1
10	GTI-404	Spreader Valve	1
▲11	GTI-413	Fluid Needle	1
*12	JGS-72-K10	Gasket Kit (Teflon) (Kit of 10)	2
16	MBD-19-K10	Spring and Pad (Kit of 10)	1
17	GTI-414	Needle Adjusting Screw	1
18	KK-5059	Bushing, Spring, Pad and Knob Kit	1
25	JGS-449-1	Air Valve Assembly	1
+26	P-MB-51	Air Inlet Nipple 1/4" NPS(M)	1
29	JGS-478	Stud and Screw Kit	1
31	JGS-477-1	Trigger Stud, Screw Kit	1
*32	KGP-13-K5	Cup Gasket (Kit of 5) (Not Shown)	1
36	GTI-428-K5	Clip, Seal and Pin (Kit of 5 Each)	1
37	192219	Gun Holder, Coated (Not Shown)	1
38	KK-5060	Air Cap Cleaning Kit (Not Shown)	1

* (KK-5058-2) Gun Repair Kit includes a quantity of necessary parts.
Suffices: -K5 designates kit of multiple parts. Example: JGA-4035-K5 is a kit of 5 packings.

Chart 1 Air Cap & Baffle Combinations

No. Stamped on Parts		Set		CFM@ Cap Pressure				
Air Cap Part No.	Baffle	Ref. No. 4 Air Cap	Ref. No. 7 Baffle Assy.	2 psi	4 psi	6 psi	8 psi	10 psi
2000	(Not Stamped)	GTI-407-2000	GTI-425	7.3	10.4	12.8	14.7	16

NOTE: Gun Repair Kit (KK-5058-2) Contains:

Ref. No.	Description	Qty.
6	Baffle Seal	1
8	Packing	1
12	Gasket Kit	2
14	Fluid Needle Spring	1
15	Spring Pad	1
19	Air Valve Spring	1
20	Air Valve	1
22	U Cup Seal	1
23	Washer	1
24	Snap Ring	1
32	Fluid Cup Gasket	1
33	Retaining Clip	1
34	Seal	1
35	Pin	1

Parts marked with a * are only available in kit KK-5058-2.

NOTE: See SB-4-043 for GFC-502 Cup parts breakdown.

Chart 2 Fluid Tip & Needle

Fluid Needle Model No.		
GTI-413		
Fluid Tip Model No.	Tip Size (I.D.)	
	In.	mm
GTI-213-12 ◆	.047	1.2
GTI-213-13 ◆	.051	1.3
GTI-213-14 ◆	.055	1.4
GTI-213-15	.059	1.5
GTI-213-16 ◆	.063	1.6
GTI-213-18	.070	1.8
GTI-213-20 ◆	.079	2.0
GTI-213-22	.086	2.2

◆ Optional



World Headquarters
ITW Industrial Finishing
Devilbiss
195 Internationale Blvd.
Glendale Heights, IL 60139
630-237-5000
Fax 630-237-5011
www.devilbiss.com

