

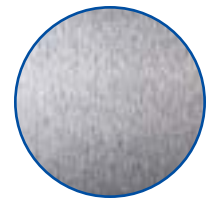

Finish Line II Gravity Feed
Spray Gun

Finish Line II

Gravity Feed Spray Gun

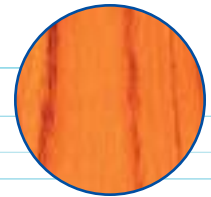
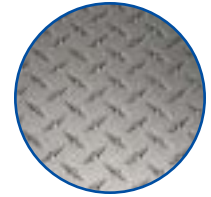

Durable, High Quality Construction

- High grade aluminum gun body
- Aluminum retaining ring and adjusting knobs
- Replaceable threaded baffle for economical servicing
- Alloyed resin handle keeps gun weight to a minimum
- Gun washer safe

Precision Engineered To Produce Well-Atomized, Uniform Spray Patterns

- Economically-priced
- Available in HVLP or conventional models
- Accurate, repeatable settings
 - Pointers on fluid and fan controls
- Stainless steel fluid needle and alloy resin fluid tip
- Less time spent on refills
 - 32 oz. aluminum cup (GFC-502)
- Quick clean-up and upside-down spraying with no cup leaks with E-Z Liner™ disposable cup liners

Gravity Feed Model Includes:

- 32 oz. aluminum cup
- (4) E-Z Liner™ disposable cup liners (OMX-70-K48)
- 1.4 mm fluid tip (conventional)
- 1.4 mm and 1.6 mm fluid tips (HVLP gun)
- Air adjusting valve with gauge (HAV-501) (HVLP gun)
- Gun hook, spray lube, fluid filter

Finish Line II Gravity Feed Spray Gun

Technical Specifications

HVLP Model (FLG-635)

23 psi inlet pressure delivers 10 psi air cap pressure
at 11.4 cfm air volume

(FLG-463) Air Cap Test Kit

Note: Gun trigger must be pulled when adjusting air inlet pressure.

Conventional Model (FLG-615)

9.9 cfm @ 40 psi inlet pressure

FINISHLINE 
By DeVilbiss

I-2176

Finish Line II Gravity Feed Spray Gun

Customer Service 1.800.992.4657

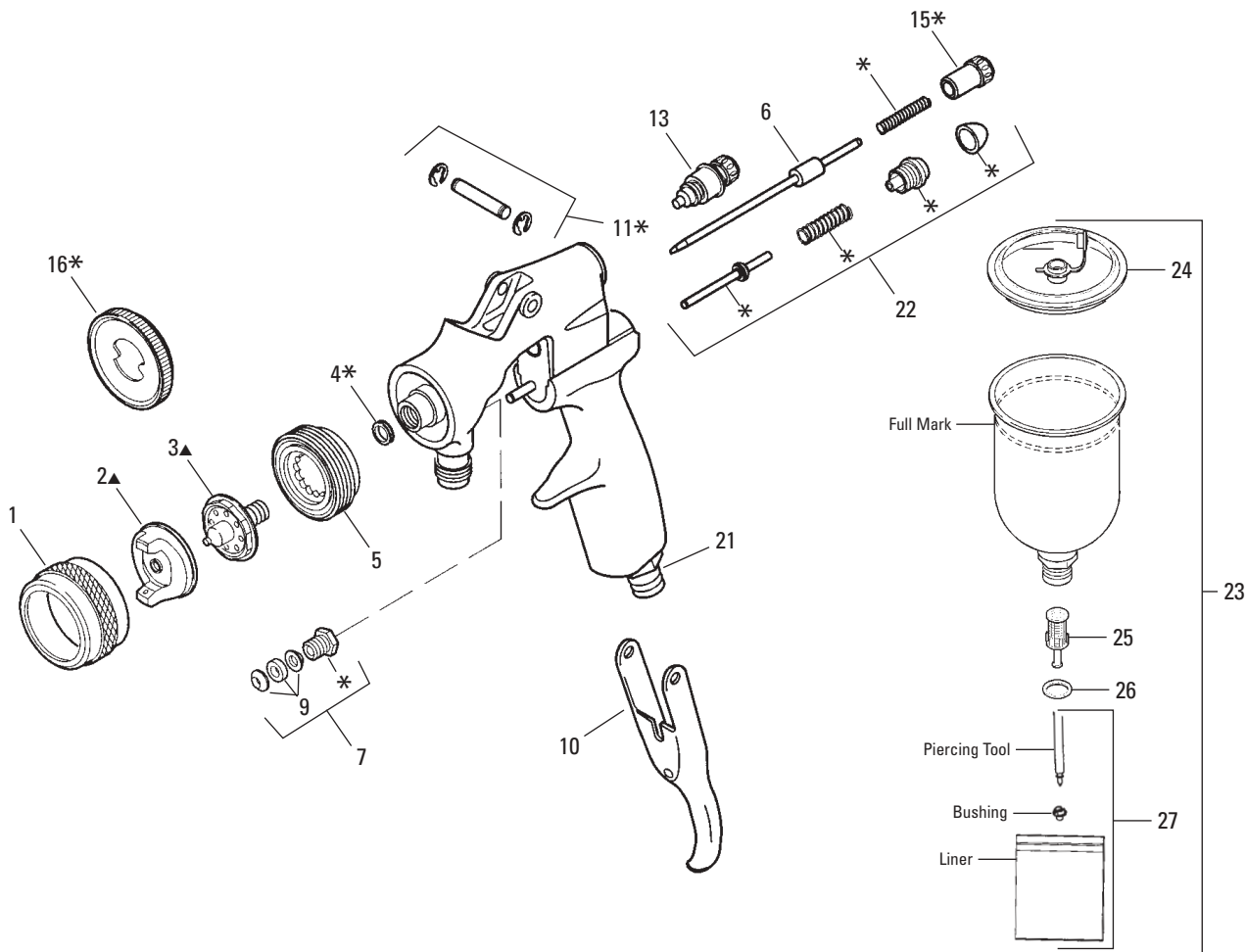

DETAIL #8
3-Piece Needle Packing Assembly

Ref. No.	Model No.	Description	Ind. Parts Required
1	FLG-101-K2	Retaining Ring (Kit of 2)	1
2	See Chart 1	Air Cap	1
3	See Chart 1	Fluid Tip (includes Ref. #4)	1
*4	FLG-4-1-K5	Fluid Tip Seal (Kit of 5)	1
5	FLG-105	Baffle	1
6	FLG-431	Fluid Needle	1
*7	FLG-440-K5	Packing Kit (includes 1 packing nut and 5 packing sets)	1
9	JGA-4035-K5	Packing Kit (Kit of 15)	1
10	FLG-412	Trigger	1
*11	FLG-8-K2	Trigger Stud Kit (Kit of 2)	1
13	FLG-416	Spreader Adjustment Valve	1
*15	FLG-109-K2	Needle Adjusting Screw (Kit of 2)	1
*16	FLG-111-K2	Fluid Tip Tool (Kit of 2)	1
21	FLG-40	Air Inlet Adapter	1
22	FLG-414	Air Valve Service Kit	1
23	GFC-502	Metal Gravity Feed Cup	1
24	GFC-404-K2	Disposable Lid Kit (Kit of 2)	1
25	KGP-5-K5	Filter Kit (Kit of 5)	1
26	KGP-13-K5	Cup Gasket (Blue) (Kit of 5)	1
*27	OMX-70-K48	Disposable Liner Kit (Kit of 48)	1

* A quantity of necessary parts is included in Repair Kit FLG-480 (order separately) for complete gun repair and should be kept on hand for service convenience.

• Kit includes: 1 Piercing Tool, 48 Liners, and Drain Bushings.

FinishLine Gravity Feed Spray Guns

Model No.	Type	Fluid Tip(mm)	Air Cap	Applications
FLG-635-316	HVLP	1.6/1.4♦	#3	General purpose, light to medium viscosity materials
FLG-615-114	Conventional	1.4	#1	General purpose, light to medium viscosity materials

♦ HVLP models come standard with two sizes of fluid tips.

▲ Air Cap & Fluid Tip Chart #1

Spray Gun Model No.	No. on Air Cap	Ref. No. 2 Air Cap Model No.	Ref. No. 3 Fluid Tip Model No.	Fluid Tip Size
FLG-615-114	1	FLG-1-1	FLG-102-14K	1.4 (Std.)
FLG-635-316	3	FLG-1-3	FLG-102-16K	1.6 (Std.)
			FLG-102-14K	1.4 (Std.)
			FLG-102-18K ■	1.8 (Opt.)
			FLG-102-22K ■	2.2 (Opt.)

■ Optional tips for FLG guns available as service parts only.



World Headquarters
ITW Industrial Finishing
DeVilbiss
195 Internationale Blvd.
Glendale Heights, IL 60139
630-237-5000
Fax 630-237-5011
www.devilbiss.com

