

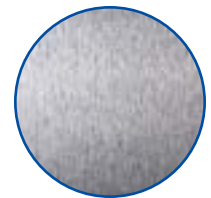

Finish Line II Siphon and Pressure Feed Spray Gun

Finish Line II Siphon and Pressure Feed Spray Gun

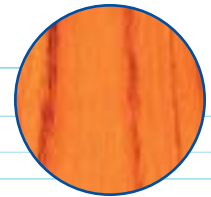
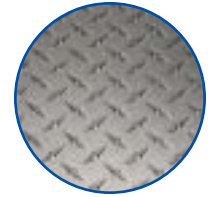

Durable, High Quality Construction

- High grade aluminum gun body
- Aluminum retaining ring and adjusting knobs
- Replaceable threaded baffle for economical servicing
- Alloyed resin handle keeps gun weight to a minimum
- Gun washer safe

Precision Engineered To Produce Well-Atomized, Uniform Spray Patterns

- Economically-priced
- Available in HVLP or conventional models
- Accurate, repeatable settings
 - Pointers on fluid and fan controls
- Stainless steel fluid needle and alloy resin fluid tip
- One-quart aluminum “drip free” suction cup (FLG-606, FLG-626)

Siphon Feed Models Include:

- One-quart aluminum suction feed cup (TGC-545)
- 1.6 mm fluid tip (conventional gun)
- 2.2 mm and 1.8 mm fluid tips (HVLP gun)
- Air adjusting valve with gauge (HAV-501) (HVLP gun)

Pressure Feed Model Includes:

- 1.6 mm tip

Note: Pressure feed model can be used with a one quart pressure feed cup, a two quart remote pressure cup or a paint tank. Order separately.

Finish Line II Siphon and Pressure Feed Spray Gun

Technical Specifications

HVLP Model (FLG-513, 626)

23 psi inlet pressure delivers 10 psi air cap pressure at 11.4 cfm air volume

(FLG-463) Air Cap Test Kit

Note: Gun trigger must be pulled when adjusting air inlet pressure.

Conventional Model (FLG-606)

9.9 cfm @ 40 psi inlet pressure



Refer to Service Bulletin: SB-2-601

Finish Line II Siphon and Pressure Feed Spray Gun

Customer Service 1.800.992.4657

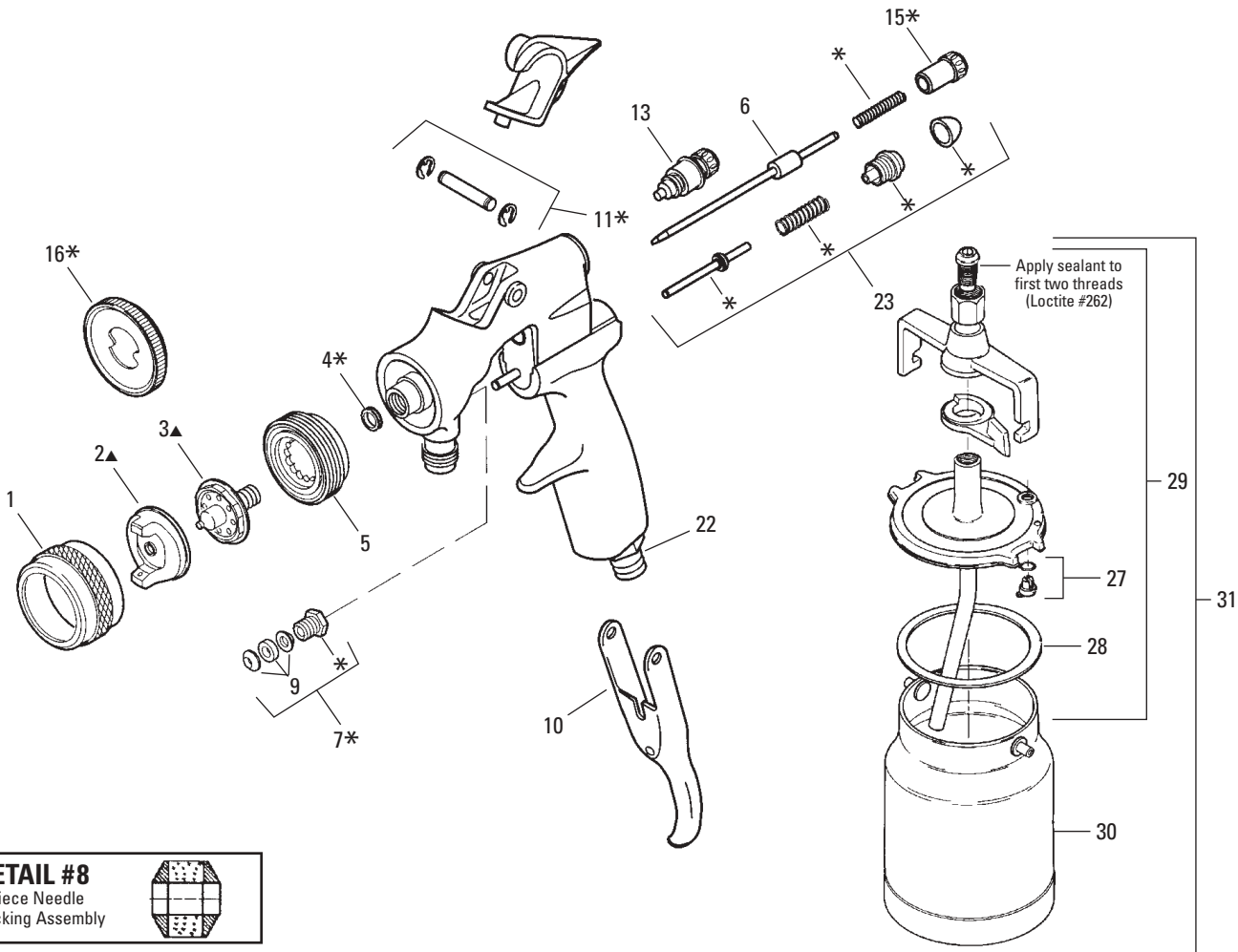

DETAIL #8

3-Piece Needle Packing Assembly



Ref. No.	Model No.	Description	Ind. Parts Required
1	FLG-101-K2	Retaining Ring (Kit of 2)	1
2	See Chart 1	Air Cap	1
3	See Chart 1	Fluid Tip (includes Ref. #4)	1
*4	FLG-4-1-K5	Fluid Tip Seal (Kit of 5)	1
5	FLG-105	Baffle	1
6	FLG-431	Fluid Needle	1
*7	FLG-440-K5	Packing Kit (includes 1 packing nut and 5 packing sets)	1
9	JGA-4035-K5	Packing Kit (Kit of 15)	1
10	FLG-412	Trigger	1
*11	FLG-8-K2	Trigger Stud Kit (Kit of 2)	1
13	FLG-416	Spreader Adjustment Valve	1
*15	FLG-109-K2	Needle Adjusting Screw (Kit of 2)	1
*16	FLG-111-K2	Fluid Tip Tool (Kit of 2)	1
22	FLG-40	Air Inlet Adapter	1
23	FLG-414	Air Valve Service Kit	1
+27	TGC-407-1-K3	Drip Free Valve and Gasket (Kit of 3)	1
+28	TGC-9-K5	Tri Seal® Lid Gasket (Kit of 5)	1
29	TGC-404	Lid Assembly (Quart)	1
30	KR-428-2	Suction Cup Assembly (Quart)	1
31	TGC-545	Suction Cup Assembly (includes Ref. Nos. 27-30)	1

* A quantity of necessary parts is included in Repair Kit FLG-480 (order separately) for complete gun repair and should be kept on hand for service convenience.

+ KK-5007 Repair Kit includes enough parts to repair one complete assembly.

FinishLine II Siphon & Pressure Feed Spray Guns

Model No.	Type	Fluid Tip(mm)	Air Cap	Applications
FLG-626-322	HVLP Siphon Feed	2.2/1.8	#3	General purpose, light to medium viscosity materials
FLG-606-116	Conventional Siphon Feed	1.6	#1	General purpose, light to medium viscosity materials
FLG-513-316	HVLP Pressure Feed	1.6	#3	General purpose, light to medium viscosity materials

▲ Air Cap & Fluid Tip Chart #1

Spray Gun Model No.	No. on Air Cap	Ref. No. 2 Air Cap Model No.	Ref. No. 3 Fluid Tip Model No.	Fluid Tip Size
FLG-513-316	3	FLG-1-3	FLG-102-16K	1.6 (Std.)
FLG-606-116	1	FLG-1-1	FLG-102-16K	1.6 (Std.)
FLG-626-322	3	FLG-1-3	FLG-102-22K	2.2 (Std.)
			FLG-102-18K	1.8 (Std.)
			FLG-102-14K ■	1.4 (Opt.)

■ Optional tips for FLG guns available as service parts only.



World Headquarters
ITW Industrial Finishing
Devilbiss
195 Internationale Blvd.
Glendale Heights, IL 60139
630-237-5000
Fax 630-237-5011
www.devilbiss.com

