



Dubois Mist Coater™

Patent Nos. US 6,746,535 & US 6,929,696



UVS-12 w/Exhaust System



UVS-24 w/out Exhaust System

Dubois Equipment produces a complete line of Mist Coaters™ that are specifically designed for the application of 100% solids UV coating to 3-dimensional contoured parts. There are many benefits associated with the application of 100% solids UV coating, some of which are shown below:

- No VOCs
- Durable finish
- Reduced exhaust air and air make-up
- Reduced cycle time with nearly instant cure and no post cure
- No reconstituting of reclaimed coating
- Lower energy costs
- Lower coating costs

Standard Mist Coaters™ Configurations:

UVS-12
12" max. width

UVS-24
24" max. width

UVS-36
36" max. width

Our Mist Coaters™ provide precision coating as low as 0.2 mil with the ability for a smooth, consistent finish on uneven surfaces such as mouldings, raised panel doors, cabinet doors, face frames, and other similar components including hardwood flooring. All units are complete with fixed spray guns, pump system, and overspray recovery system. The overspray recovery system collects both the overspray coating on the conveyor belt and in the exhaust air.

Key Mist Coater™ features include:

- Easy set-up and adjustment
- Can accommodate varying part dimensions without set-up changes
- Minimal End of Shift Clean-up
- Overspray recovery system, 98%+



Dubois 3-D UV Oven

Patent Pending



UV3D-52 UV Oven



UV3D-12 UV Oven

Dubois Equipment produces a complete line of 3-dimensional UV ovens. The Dubois 3-D UV Oven is the result of designing a machine from the ground up to properly cure three-dimensional substrate. By providing both equal dose and peak intensity to all surfaces of the substrate, the most efficient cure is obtained. This breakthrough design provides for lower coating cost, lower energy consumption, improved coating performance, and elimination of safety issues due to uncured edges. This proven technology has greatly enhanced the energy efficiency, safety, and overall performance of UV coating systems.

Standard UV3D Oven Configurations:

UV3D-12
12" max. width

UV3D-24
24" max. width

UV3D-36
36" max. width

UV3D-52
52" max. width

Our new UV3D ovens can also be supplied with bottom UV lamps depending on your application.

Key UV3D Oven Features include:

- Innovative irradiator reflector design
- Irradiators are easily removed for quick maintenance and less downtime
- Filtered air system maintains cleaner lamps and irradiators
- Even dose and intensity on all surfaces (edges & top) across the entire width of the belt
- Eliminates uncured edges



Dubois 100% Solids UV Coating Solution

The attached line layouts include machines capable of applying and curing 100% solids UV coating for either a one pass or multiple pass process depending on the quality level you require for your finished product. If a multiple pass would be required, the product would need to be sanded between coats. Dubois offers automatic de-nib units for this purpose.

The equipment shown on the UVS-12 layout would be capable of coating and curing product at a line speed of 50 feet per minute. The line would be capable of faster line speeds by including longer irradiators in the UV Oven. The layout consists of a Model UVS-12 with coating recovery system and a Model UV3D-12 to provide 3-D UV curing of the contoured substrate.

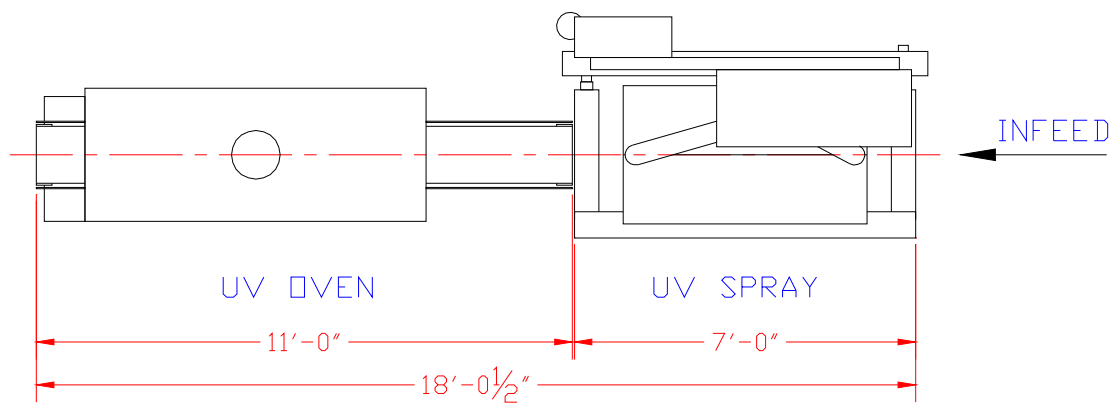

UVS-12 Layout



Dubois 100% Solids UV Coating Solution

The equipment shown on the UVS-36 layout would be capable of coating and curing product at a line speed of 35 feet per minute. The line would be capable of faster line speeds by including more lamps with the UV Oven. The layout consists of a Model UVS-36 with coating recovery system and a Model UV3D-36 to provide 3-D UV curing of the contoured substrate.

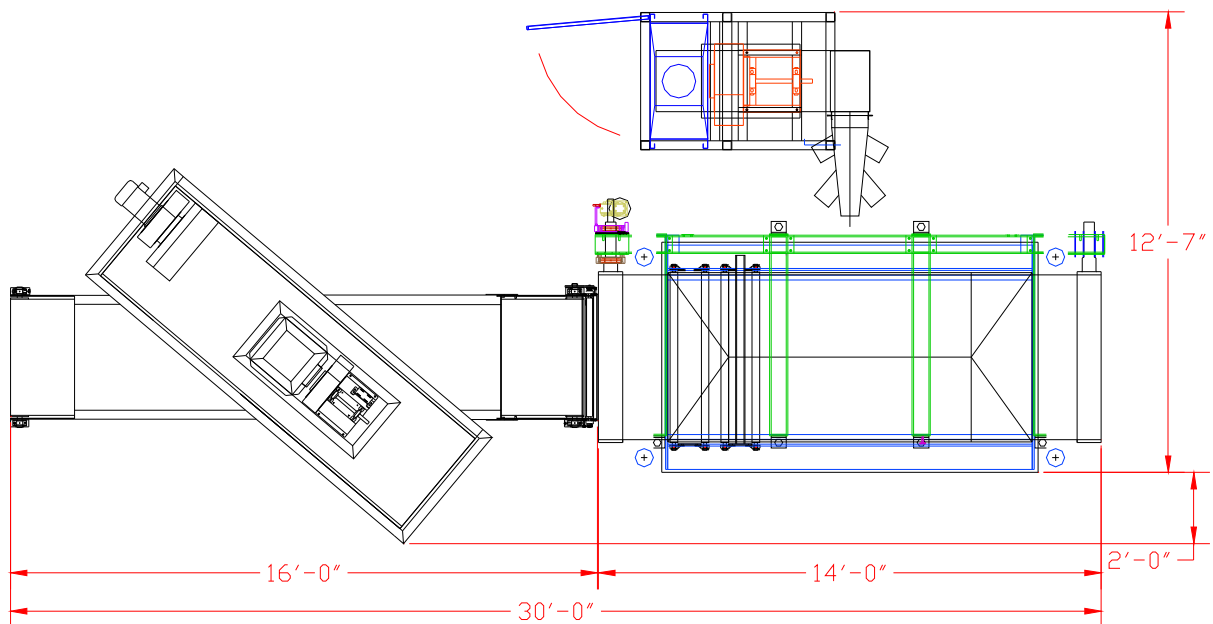

UVS-36 Layout

The actual cost of the equipment, equipment footprint, and machines required may vary depending on your specific coating needs. We will work with you to meet your equipment needs whether you require a single piece of equipment or a total system. Please contact us for current pricing.

Dubois Equipment has a fully equipped lab facility available for evaluating our equipment and your coating materials at no cost to our potential customers. We would welcome the opportunity to evaluate a sample of your products and coatings in our lab to identify your complete coating system or your individual equipment needs.



Cost Comparison

Why change to 100% solids UV coating?

When considering the change to 100% solids UV coating, you will need to determine the cost effectiveness as compared to the conventional coating process. To make a comparison of the coating costs, you must factor in the aspects of each process. The formula below can be used to make a comparison of actual applied coating costs to achieve the same end result:

$$(\# \text{ gal used}) \times (\% \text{ solids/gal}) \times (\% \text{ transfer efficiency}) = (\# \text{ gal of solids applied})$$

100% Solids UV Coating Approach:

- 100% solids content per gallon
- 98% transfer efficiency
- **0.98 gal** of solids applied to substrates per gallon used

Conventional Coating Approach:

- 35% solids content per gallon
- 50% transfer efficiency
- **0.175 gal** of solids applied to substrates per gallon used

Based on the calculated solids applied above, for every gallon of 100% Solids UV Coating used, you will have to use 5.6 gallons of Conventional Coating to achieve the same dry build on your products. The above information is now used below to make a direct comparison of coating cost savings when using 100% solids UV coating.

Conventional Coating used/day	100% Solids required to get same dry build	Coating Cost savings/day	Annual Coating Cost Savings
1 gallon	0.18 gallon	\$ 11	\$ 2,750
10 gallons	1.8 gallons	\$ 110	\$ 27,500
100 gallons	18 gallons	\$ 1,100	\$ 275,000

What is the applied cost per square foot of 1 dry mil?

Conventional Coating: \$ 0.071 / ft ² @ 1 dry mil
UV 100% Solids Coating: \$ 0.032 / ft ² @ 1 dry mil

For 1 wet Mil thickness of coating coverage, a gallon of coating covers approximately 1,604 ft². To determine the cost per square foot of 1 dry Mil, use the following:

$$(\text{dry Mil ft}^2/\text{gal applied}) = (\% \text{ solids}) \times (\% \text{ transfer efficiency}) \times (1604 \text{ ft}^2/\text{gal})$$

$$\text{Cost per ft}^2 \text{ @ 1 dry Mil} = (\text{Cost/gal}) / (\text{dry Mil ft}^2/\text{gal})$$

Note: All pricing information shown above is based on a \$ 50 per gallon of 100% solids UV coating and \$ 20 per gallon for conventional coating.