

# Water Wash Booths



Your spray booth is an investment that pays many dividends by providing cleaner painting environment for superior quality finishes, and means for increasing productivity, and better working conditions.

- ❖ EXTREMELY EFFICIENT IN REMOVING AIRBORNE PARTICULATE
- ❖ CONSISTENT HIGH LEVEL OF CAPTURE EFFICIENCY FOR HIGH VOLUME APPLICATIONS
- ❖ AIR CLEANED USING WATER SCRUB AND IMPINGEMENT TECHNOLOGIES IN TANDEM
- ❖ PARTICULATE-LADEN AIR SCRUBBED FOUR TIMES BEFORE DISCHARGE
- ❖ TIME-TESTED DESIGN, PROVIDING SUPERIOR OVERSPRAY REMOVAL FOR OVER FIFTY YEARS



# Floor and Conveyor Dynaprecipitor Spray Booths

**Team Blowtherm's Dynaprecipitor Water Wash Spray Booth** handles a larger variety of paints in a wider range of viscosities and drying speeds, at higher production rates than any of the conventional spray booths.

This booth employs two well-known engineering principles to remove paint particles from exhaust air in painting operations. First, by drawing air through a continuous curtain of moving water, suspended paint particles are scrubbed out. Second, when air carrying paint particles makes a sudden change in direction of flow, centrifugal force slings the solid particles out of the air stream. Entrained paint particles are thrown against adjacent walls and curtains. Water then flushes the particulate into the collecting pan. Through these two actions, air reaching the exhaust stack is virtually free of airborne particles.

The wash water should be treated (compounded). This causes the paint particles to coagulate and allows convenient skimming when cleaning out the collection pan. Team Blowtherm recommends the customer consult a reputable chemical supplier for the proper compound to suit the material being sprayed.

Correctly engineered water wash spray booths provide an extremely efficient means for removing paint particles from the exhausted air. In addition, they are the most acceptable type of spray booth for all health, fire, and building codes.

## CONSTRUCTION FEATURES

This booth is constructed of 18-gauge galvanized panels.

It features:

- an upper and lower wash chamber
- large capacity collecting pan
- slotted water intake pipe to insure sediment free water
- circulating water to maintain a constantly flushed system
- removable manifold for easy maintenance
- hinged water curtain to allow easy access to the rear of the collecting pan
- door located just below the fan for easy maintenance

The booth saves floor space. Its short-depth wash unit gives water-wash-spray-booth advantages while occupying conventional booth space.

An automatic water level control supplies make-up water to compensate for evaporation losses.

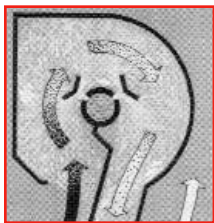

**Upper centrifugal wash chamber:** Here, most of the paint particles are separated from the exhaust air. This separation is accomplished by centrifugal force on the paint particles as the air abruptly changes direction of flow while simultaneously being forced to pass through powerful water sprays.



**Lower wash chamber:** In the lower wash chamber, the exhaust air must pass through an unbroken curtain of water. Again, water scrubbing and centrifugal force combine to remove the remaining paint particles before the air passes to the exhaust chamber.

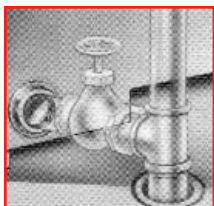

**Recessed drain:** The recessed drain supplied insures complete removal of water from the collecting pan. This feature simplifies the cleaning operation. NOTE: Check with local codes for disposal

**Dynaprecipitor Cross-Section:** Booths are available in 7', 8' and 10' heights. Shown below is the air flow through a typical Dynaprecipitor Water Wash Booth.

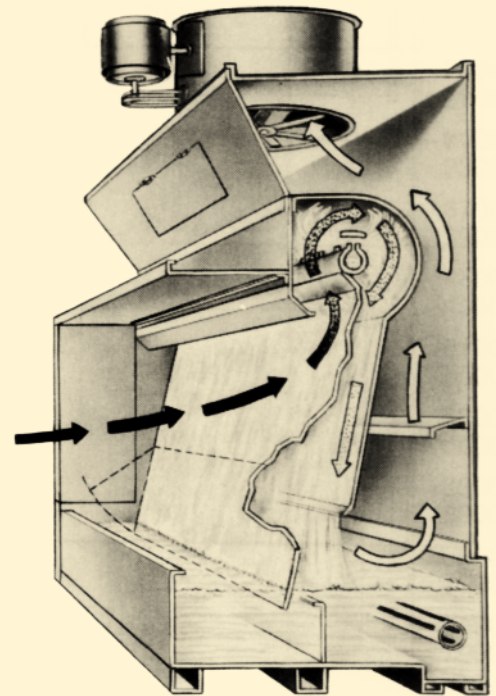

Dynaprecipitor® is a registered trademark of Team Blowtherm.

## OPERATION FEATURES

**Stacks and fan:** Paint particles practically never reach this zone. The stack area stays cleaner longer.

**Exhaust air washed 4 times:** Paint particles are scrubbed out and trapped in collecting pan.

**Access door:** The location will allow easy inspection, repair, or replacement of the fan parts.

**Unbroken water curtain:** Manifold-deflector plate assembly disperses water evenly and can be easily removed without special tools.

**Circulating system:** Circulating water forms a continuous, constantly flushed system that has no sediment-accumulating dead ends. Rate of water flow is quickly adjustable. No new water need be added except to compensate for slight daily evaporation.

**Booth stays cleaner:** Every paint-collecting surface is water-scrubbed.

**Easy maintenance:** Hinged front water curtain permits easy skimming of coagulated paint particles from collecting pan. Optional automatic centrifugal separators are available.

**Clog-free water circulating system:** Intake pipe is above the pan floor to assure a sediment-free supply of water. System is self-flushing.

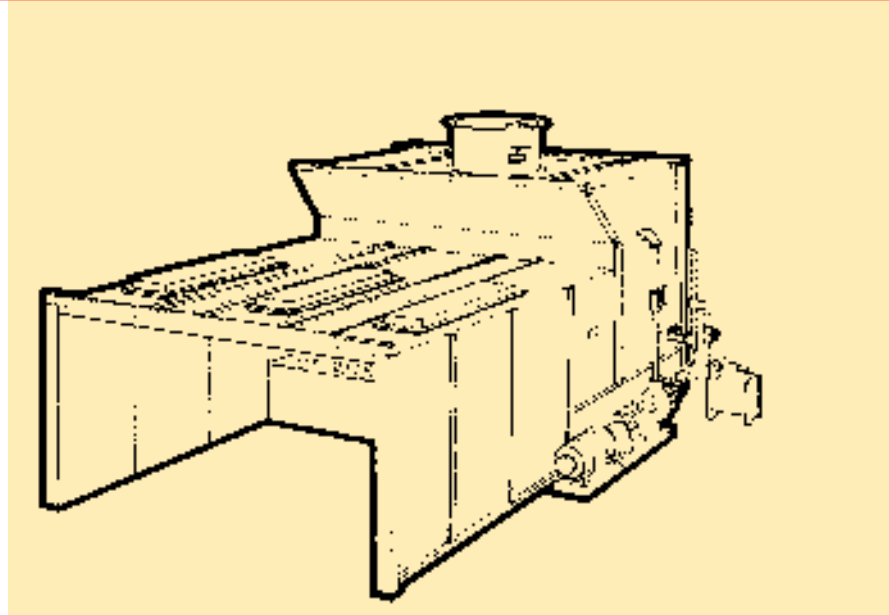

### 7'-0" DYNAPRECIPITOR WATER WASH BOOTH 125 FPM MIN. FACE VELOCITY, FLOOR-TYPE

Model No.	Work Dim.		Overall Dim.			Airflow SCFM	Fan & Motor		Pump		Fixture	Ship. Wt. Lbs.
	A	B	C	D	E		Dia	H.P.	GPM	H.P.		
WE-476	4'-0"	6'-10"	5'-0"	10'-2"	10'-1"	4860	24"	1 1/2	172	3	1	2100
WE-576	5'-0"	6'-10"	5'-0"	10'-2"	10'-1"	4860	24"	1 1/2	200	3	1	2300
WE-676	6'-0"	6'-10"	5'-0"	10'-2"	10'-1"	5400	24"	2	228	3	1	2500
WE-876	8'-0"	6'-10"	5'-0"	10'-2"	10'-1"	8091	24"	3	284	5	1	3200
WE-1076	10'-0"	6'-10"	5'-0"	10'-2"	10'-1"	10253	24"	5	340	5	2	3800
WE-1276	12'-0"	6'-10"	7'-6"	10'-2"	12'-7"	11118	34"	5	396	5	2	4800
WE-1476	14'-0"	6'-10"	7'-6"	12'-2"	12'-7"	12816	34"	5	452	7 1/2	2	5400
WE-1676	16'-0"	6'-10"	7'-6"	12'-2"	12'-7"	16306	34"	5	508	7 1/2	3	5800
WE-1876	18'-0"	6'-10"	7'-6"	12'-2"	12'-7"	19103	40"	5	564	7 1/2	3	7200
WE-2076	20'-0"	6'-10"	7'-6"	12'-2"	12'-7"	19103	40"	5	585	7 1/2	4	7800

**8'-0" DYNAPRECIPITOR WATER WASH BOOTH 125 FPM MIN. FACE VELOCITY, FLOOR-TYPE**

Model No.	Work Dim.			Overall Dim.		Airflow SCFM	Fan & Motor		Pump		Fixture	Ship. Wt. Lbs.
	A	B	C	D	E		Dia	H.P.	GPM	H.P.		
WE-486	4'-0"	7'-10"	5'-0"	10'-2"	10'-1"	4445	24"	1 1/2	172	3	1	2200
WE-586	5'-0"	7'-10"	5'-0"	10'-2"	10'-1"	5400	24"	2	200	3	1	2400
WE-686	6'-0"	7'-10"	5'-0"	10'-2"	10'-1"	6800	24"	3	228	3	1	2600
WE-886	8'-0"	7'-10"	5'-0"	10'-2"	10'-1"	8091	24"	3	284	5	1	3300
WE-1086	10'-0"	7'-10"	7'-6"	10'-2"	10'-1"	1118	34"	5	340	5	2	3900
WE-1286	12'-0"	7'-10"	7'-6"	10'-2"	12'-7"	12616	34"	5	396	5	2	4900
WE-1486	14'-0"	7'-10"	7'-6"	12'-2"	12'-7"	14295	34"	5	452	7 1/2	2	5500
WE-1686	16'-0"	7'-10"	7'-6"	12'-2"	12'-7"	19103	40"	5	508	7 1/2	3	5900
WE-1886	18'-0"	7'-10"	7'-6"	12'-2"	12'-7"	19103	40"	5	564	7 1/2	3	7300
WE-2086	20'-0"	7'-10"	7'-6"	12'-2"	12'-7"	23061	40"	7 1/2	585	7 1/2	4	7900

**10'-0" DYNAPRECIPITOR WATER WASH BOOTH 125 FPM MIN. FACE VELOCITY, FLOOR-TYPE**

Model No.	Work Dim.			Overall Dim.		Airflow SCFM	Fan & Motor		Pump		Fixture	Ship. Wt. Lbs.
	A	B	C	D	E		Dia	H.P.	GPM	H.P.		
WE-8107	8'-0"	9'-10"	7'-6"	10'-2"	12'-7"	13188	34"	5	284	5	2	3700
WE-10107	10'-0"	9'-10"	7'-6"	10'-2"	12'-7"	13188	34"	5	340	5	3	4300
WE-12107	12'-0"	9'-10"	7'-6"	10'-2"	12'-7"	16176	40"	7 1/2	396	5	3	5100
WE-14107	14'-0"	9'-10"	7'-6"	12'-2"	12'-7"	21769	40"	10	452	7 1/2	3	5600
WE-16107	16'-0"	9'-10"	7'-6"	12'-2"	12'-7"	21769	40"	10	508	7 1/2	4	6100
WE-18107	18'-0"	9'-10"	7'-6"	10'-2"	12'-7"	26376*	34"	5	564	7 1/2	4	7500
WE-20107	20'-0"	9'-10"	7'-6"	10'-2"	12'-7"	26376*	34"	5	585	7 1/2	4	8100

**7'-0" DYNAPRECIPITOR WATER WASH CONVEYOR BOOTH  
150 FPM MAX. FACE VELOCITY, FLOOR-TYPE WITH CONVEYOR OPENING CLOSED**

Model No.	Work Dim.			Overall Dim.		Airflow SCFM	Fan & Motor		Pump		Fixture	Ship. Wt. Lbs.
	A	B	C	D	E		Dia	H.P.	GPM	H.P.		
CWE-477	4'-0"	6'-10"	7'-6"	10'-2"	12'-7"	4860	24"	1 1/2	172	3	0	2100
CWE-577	5'-0"	6'-10"	7'-6"	10'-2"	12'-7"	4860	24"	1 1/2	200	3	1	2400
CWE-677	6'-0"	6'-10"	7'-6"	10'-2"	12'-7"	6877	24"	3	228	3	1	2800
CWE-877	8'-0"	6'-10"	7'-6"	10'-2"	12'-7"	9550	24"	5	284	5	1	3300
CWE-1077	10'-0"	6'-10"	7'-6"	10'-2"	12'-7"	11118	34"	5	340	5	2	3900
CWE-1277	12'-0"	6'-10"	7'-6"	10'-2"	12'-7"	12818	34"	5	396	5	2	4900
CWE-1477	14'-0"	6'-10"	7'-6"	12'-2"	12'-7"	16300	34"	5	452	7 1/2	2	5300
CWE-1677	16'-0"	6'-10"	7'-6"	12'-2"	12'-7"	17460	34"	5	508	7 1/2	3	5900
CWE-1877	18'-0"	6'-10"	7'-6"	12'-2"	12'-7"	17460	34"	5	564	7 1/2	3	7200
CWE-2077	20'-0"	6'-10"	7'-6"	12'-2"	12'-7"	23061	40"	7 1/2	585	7 1/2	4	7900

**8'-0" DYNAPRECIPITOR WATER WASH CONVEYOR BOOTH 150 FPM MIN. FACE VELOCITY  
FLOOR-TYPE WITH CONVEYOR OPENING CLOSED**

Model No.	Work Dim.			Overall Dim.		Airflow SCFM	Fan & Motor		Pump		Fixture	Ship. Wt. Lbs.
	A	B	C	D	E		Dia	H.P.	GPM	H.P.		
CWE-487	4'-0"	7'-10"	7'-6"	10'-2"	12'-7"	5345	24"	3	172	3	0	2200
CWE-587	5'-0"	7'-10"	7'-6"	10'-2"	12'-7"	7062	24"	3	200	3	1	2500
CWE-687	6'-0"	7'-10"	7'-6"	10'-2"	12'-7"	8766	24"	5	228	3	1	2700
CWE-887	8'-0"	7'-10"	7'-6"	10'-2"	12'-7"	11444	34"	5	284	5	1	3300
CWE-1087	10'-0"	7'-10"	7'-6"	10'-2"	12'-7"	14200	34"	5	340	5	2	3900
CWE-1287	12'-0"	7'-10"	7'-6"	10'-2"	12'-7"	15674	34"	5	396	5	2	5000
CWE-1487	14'-0"	7'-10"	7'-6"	12'-2"	12'-7"	19000	34"	7 1/2	452	7 1/2	2	5400
CWE-1687	16'-0"	7'-10"	7'-6"	12'-2"	12'-7"	20259	40"	7 1/2	508	7 1/2	3	5900
CWE-1887	18'-0"	7'-10"	7'-6"	12'-2"	12'-7"	22888*	34"	5	564	7 1/2	3	7300
CWE-2087	20'-0"	7'-10"	7'-6"	12'-2"	12'-7"	22888*	34"	5	585	7 1/2	4	8000

\*Both 18 and 20 foot booths are supplied with 2 fans.

# NO PUMP WATER WASH BOOTH FLOOR-TYPE AND CONVEYOR-TYPE

## NO PUMP Spray Booths

Without benefit of pump or water-spraying manifold, Team Blowtherm's NO PUMP SPRAY BOOTH uses the highly effective scrubbing action of a water wash to separate paint particles from exhaust air. By ingenious channeling of the paint-laden exhaust air through a "water tunnel" the NO PUMP system eliminates pumps, piping, filters, manifolds, and nozzles.

### How It Works

Paint-laden air is drawn into the washing chamber at high velocity through an opening between the entrainment plate and water surface (see illustration). The controlled dimension of this opening and the specially designed profile of the entrainment plate force the high velocity air to become severely turbulent, splash up water, and become thoroughly mixed with the overspray.

Next, this rapidly moving mixture of air, paint particles, and water droplets strikes the distribution plate. The mixture is forced to change direction abruptly and to flow upward through a series of baffles.

The "mixture" flow changes direction 11 times during its passage through the baffle section. At each change centrifugal force separates air from paint particles and from water droplets. The resulting rain of water, particularly from the lower baffles, serves as an additional water curtain for scrubbing the incoming spray laden air. All of the paint spray that is separated from the air falls back into the water tank.

### Features:

- 12 and 14 gauge galvanized welded washer assembly.
- Standard panel work area enclosure, 18 gauge galvanized.
- Chemically treated water prevents flotation of spray residue. Water surface residue skimming eliminated. Contact local compounds supplier.
- Automatic water level control for maintaining air velocity through entrainment plate gap to within + 1%.
- Centrifugal exhaust blower with clean-out door and drain. Type "C" spark resistant construction.
- Optional installed position of exhaust blower outlet for direction of discharge (90° increments).
- Inside-accessible ETL-listed 4-tube light fixtures (includes color corrected T-8 tubes).

### Easy Assembly

NO PUMP washer is shipped in 3 major all-welded sections for ease of field assembly:

1. Pan
2. Wash Chamber
3. Booth Adapter

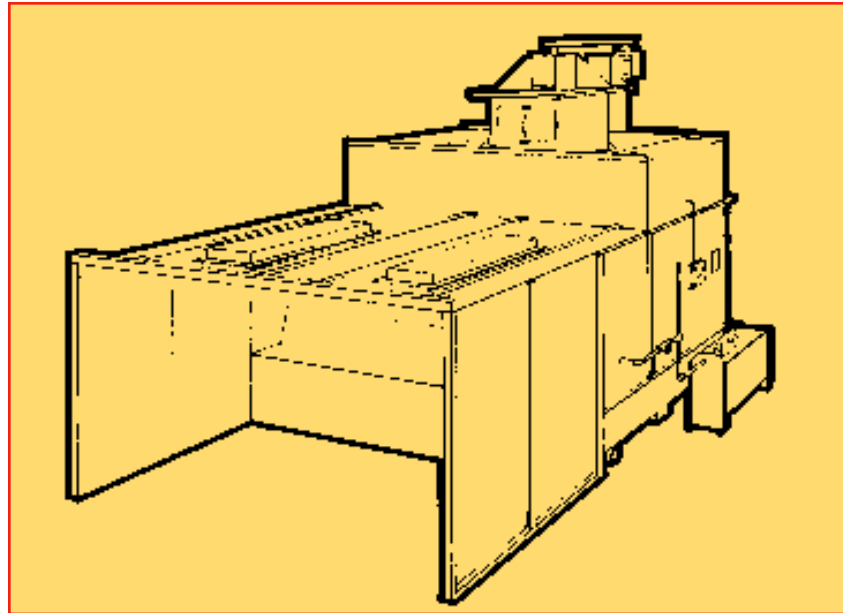

### Water Treatment

The water in the tank should be treated with the proper compound to suit the material being sprayed in order that the paint particles be made non-tacky and settle to the bottom of the tank where they agglomerate as a soft, foamy residue. Residue buildup may approach to within 2 inches of the water surface without adversely affecting the "NO PUMP" action in the water tunnel. Residue removal is very infrequent, even in high production painting. Optional cyclonic separator available.

### Precise Water Level Control

The gap between the water surface and entrainment plate is kept with + 1% of its optimum dimension. This is accomplished with a Team Blowtherm Float Box with Water Level Control Unit. This unit is located outside the booth proper - isolated from contaminating water and spray. Yet it is directly connected hydraulically to the water tank and senses water level changes immediately and accurately. Its external location gives it maximum accessibility for inspection and calibration.

### Ordering Notes:

1. Right side water level control valve and drain outlet standard. Left side available on special order. Rear available at additional cost.
2. Top exhaust standard. Consult Team Blowtherm representative if more than 25 ft. of exhaust duct is required.
3. Optional discharge elbow and transition, see chart.
4. Outside mounting of exhaust blower on heavy gauge steel stack available on special order.
5. TEFC motors are standard. Motor starters and explosion-proof motors are available at extra cost.
6. Compound (percent concentration) meter. See accessories page.

# NO PUMP WATER WASH BOOTH FLOOR-TYPE AND CONVEYOR-TYPE

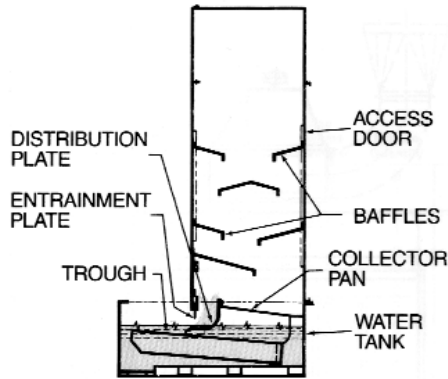

## DISCHARGE ELBOW AND TRANSITION

Blower Size	Discharge Elbow	Discharge Transition	Dia.
16	DE-16	DT-16	24"
18	DE-18	DT-18	24"
20	DE-20	DT-20	24"
22	DE-22	DT-22	24"
24	DE-24	DT-24	34"
27	DE-27	DT-27	34"
30	DE-30	DT-30	34"
33	DE-33	DT-33	42"

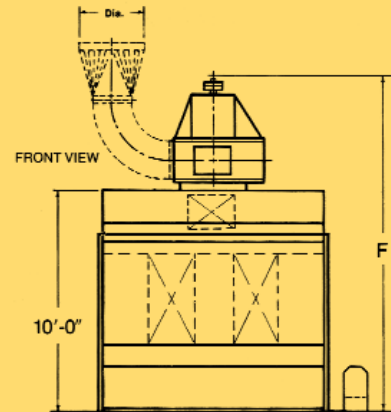
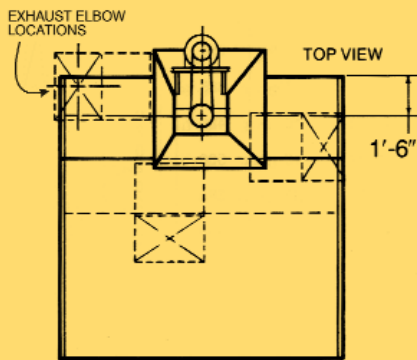

## NO PUMP WATER WASH BOOTH FLOOR-TYPE

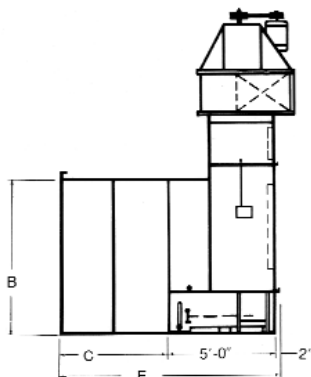
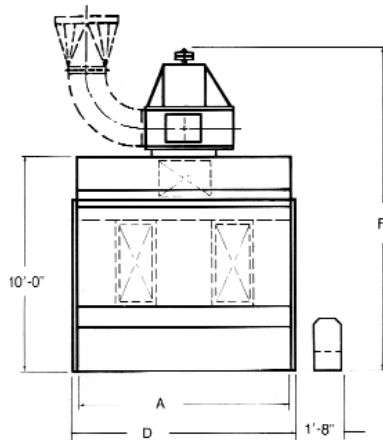

## NO PUMP WATER WASH BOOTH CONVEYOR-TYPE

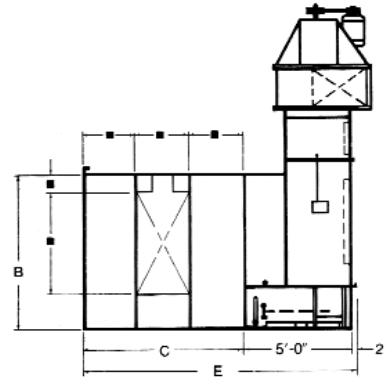
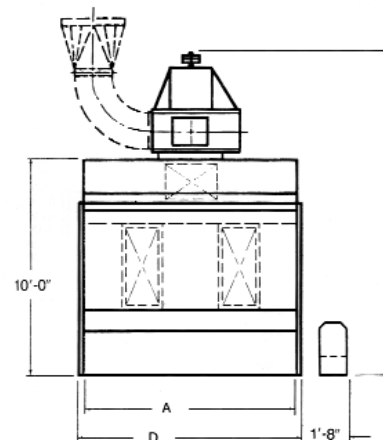

# NO PUMP WATER WASH BOOTH FLOOR-TYPE

## 7'-0" NO PUMP WATER WASH BOOTH 125 FPM MIN. FACE VELOCITY, FLOOR-TYPE

Model No.	Work Dimensions				Overall Dimensions		Flow Rate @4.2" Water Col.SCFM	Fan & Motor		Pan Volume Gallons	Fixture Quantity	Ship. Wt. Lbs.
	A	B	C	D	E	F		Dia	H.P.			
NPB-576	5'-0"	6'-10"	5'-0"	5'-0"	10'-2"	13'-4"	4400	18	5	210	1	2600
NPB-676	6'-0"	6'-10"	5'-0"	6'-0"	10'-2"	13'-8"	5200	20	7 1/2	250	1	2900
NPB-876	8'-0"	6'-10"	5'-0"	8'-0"	10'-2"	14'-2"	7000	24	7 1/2	335	1	3700
NPB-1076	10'-0"	6'-10"	5'-0"	10'-0"	10'-2"	14'-4"	8700	24	10	420	2	4300
NPB-1276	12'-0"	6'-10"	7'-6"	13'-0"	12'-8"	14'-8"	10500	27	10	500	2	5200
NPB-1476	14'-0"	6'-10"	7'-6"	15'-0"	12'-8"	14'-8"	12300	27	15	585	2	6300
NPB-1676	16'-0"	6'-10"	7'-6"	17'-0"	12'-8"	14'-11"	14000	30	15	670	3	7200
NPB-1876	18'-0"	6'-10"	7'-6"	19'-0"	12'-8"	14'-2"	15800	24*	7 1/2	755	3	7700
NPB-2076	20'-0"	6'-10"	7'-6"	21'-0"	12'-8"	14'-4"	17500	24*	10	840	4	8700

## 8'-0" NO PUMP WATER WASH BOOTH 125 FPM MIN. FACE VELOCITY, FLOOR-TYPE

Model No.	Work Dimensions				Overall Dimensions		Flow Rate @4.2" Water Col.SCFM	Fan & Motor		Pan Volume Gallons	Fixture Quantity	Ship. Wt. Lbs.
	A	B	C	D	E	F		Dia	H.P.			
NPB-586	5'-0"	7'-10"	5'-0"	5'-0"	10'-2"	13'-8"	5000	18	7 1/2	210	1	2700
NPB-686	6'-0"	7'-10"	5'-0"	6'-0"	10'-2"	14'-2"	6000	20	7 1/2	250	1	2900
NPB-886	8'-0"	7'-10"	5'-0"	8'-0"	10'-2"	14'-4"	8000	24	7 1/2	335	1	3700
NPB-1086	10'-0"	7'-10"	5'-0"	10'-0"	10'-2"	14'-8"	10000	27	10	420	2	4400
NPB-1286	12'-0"	7'-10"	7'-6"	13'-0"	12'-8"	14'-8"	12000	27	15	500	2	5300
NPB-1486	14'-0"	7'-10"	7'-6"	15'-0"	12'-8"	14'-11"	14000	30	15	585	2	6300
NPB-1686	16'-0"	7'-10"	7'-6"	17'-0"	12'-8"	15'-4"	16000	33	15	670	3	7200
NPB-1886	18'-0"	7'-10"	7'-6"	19'-0"	12'-8"	14'-4"	18000	24*	10	755	3	7800
NPB-2086	20'-0"	7'-10"	7'-6"	21'-0"	12'-8"	14'-8"	20000	27*	10	840	4	8700

## 10'-0" NO PUMP WATER WASH BOOTH 125 FPM MIN. FACE VELOCITY, FLOOR-TYPE

Model No.	Work Dimensions				Overall Dimensions		Flow Rate @4.2" Water Col.SCFM	Fan & Motor		Pan Volume Gallons	Fixture Quantity	Ship. Wt. Lbs.
	A	B	C	D	E	F		Dia	H.P.			
NPB-8106	8'-0"	9'-10"	7'-6"	9'-0"	12'-8"	14'-8"	9600	27	10	335	2	4100
NPB-10106	10'-0"	9'-10"	7'-6"	11'-0"	12'-8"	14'-8"	12000	27	15	420	3	4300
NPB-12106	12'-0"	9'-10"	7'-6"	12'-0"	12'-8"	14'-11"	14400	30	15	500	3	5400
NPB-14106	14'-0"	9'-10"	7'-6"	15'-0"	12'-8"	15'-4"	16800	33	20	585	3	6600
NPB-16106	16'-0"	9'-10"	7'-6"	17'-0"	12'-8"	15'-4"	19200	33	20	670	3	7700
NPB-18106	18'-0"	9'-10"	7'-6"	19'-0"	12'-8"	14'-8"	21600	27*	15	755	3	8400
NPB-20106	20'-0"	9'-10"	7'-6"	21'-0"	12'-8"	14'-8"	24000	27*	15	840	4	9000

\*Both 18 and 20 foot booths are supplied with 2 fans.

# NO PUMP WATER WASH BOOTH CONVEYOR-TYPE

## 7'-0" NO PUMP WATER WASH CONVEYOR BOOTH

150 FPM MIN. FACE VELOCITY WITH CONVEYOR OPENING CLOSED

Model No.	Work Dimensions			Overall Dimensions			Flow Rate @4.2" Water Col.SCFM	Fan & Motor		Pan Volume Gallons	Fixture Quantity	Ship. Wt. Lbs.
	A	B	C	D	E	F		Dia	H.P.			
CNPB-577	5'-0"	6'-10"	7'-6"	12'-8"	12'-8"	13'-8"	5250	18	7 1/2	210	1	2600
CNPB-677	6'-0"	6'-10"	7'-6"	12'-8"	12'-8"	14'-2"	6300	20	7 1/2	250	1	2900
CNPB-877	8'-0"	6'-10"	7'-6"	12'-8"	12'-8"	14'-4"	8400	24	10	335	1	3700
CNPB-1077	10'-0"	6'-10"	7'-6"	12'-8"	12'-8"	14'-8"	10500	27	10	420	2	4300
CNPB-1277	12'-0"	6'-10"	7'-6"	13'-0"	12'-8"	14'-8"	12600	27	15	500	2	5200
CNPB-1477	14'-0"	6'-10"	7'-6"	15'-0"	12'-8"	14'-11"	14700	30	15	585	2	6300
CNPB-1677	16'-0"	6'-10"	7'-6"	17'-0"	12'-8"	15'-4"	16800	33	15	670	3	7200
CNPB-1877	18'-0"	6'-10"	7'-6"	19'-0"	12'-8"	14'-8"	18900	27*	10	755	3	7700
CNPB-2077	20'-0"	6'-10"	7'-6"	21'-0"	12'-8"	14'-8"	21000	27*	10	840	4	8700

## 8'-0" NO PUMP WATER WASH CONVEYOR BOOTH

150 FPM MIN. FACE VELOCITY WITH CONVEYOR OPENINGS CLOSED

Model No.	Work Dimensions			Overall Dimensions			Flow Rate @4.2" Water Col.SCFM	Fan & Motor		Pan Volume Gallons	Fixture Quantity	Ship. Wt. Lbs.
	A	B	C	D	E	F		Dia	H.P.			
CNPB-587	5'-0"	7'-10"	7'-6"	5'-4"	12'-8"	13'-8"	6000	18	7 1/2	210	1	2600
CNPB-687	6'-0"	7'-10"	7'-6"	6'-4"	12'-8"	14'-2"	7200	22	7 1/2	250	1	2900
CNPB-887	8'-0"	7'-10"	7'-6"	8'-4"	12'-8"	14'-4"	9600	27	10	335	1	3700
CNPB-1087	10'-0"	7'-10"	7'-6"	10'-4"	12'-8"	14'-8"	12000	27	15	420	2	4300
CNPB-1287	12'-0"	7'-10"	7'-6"	13'-0"	12'-8"	14'-8"	14400	30	15	500	2	5200
CNPB-1487	14'-0"	7'-10"	7'-6"	15'-0"	12'-8"	14'-11"	16800	33	20	585	2	6300
CNPB-1687	16'-0"	7'-10"	7'-6"	17'-0"	12'-8"	15'-4"	19200	33	20	670	3	7200
CNPB-1887	18'-0"	7'-10"	7'-6"	19'-0"	12'-8"	14'-8"	21600	27*	15	755	3	7700
CNPB-2087	20'-0"	7'-10"	7'-6"	21'-0"	12'-8"	14'-8"	24000	27*	15	840	4	8700

## 10'-0" NO PUMP WATER WASH CONVEYOR BOOTH

125 FPM MIN. FACE VELOCITY, FLOOR-TYPE WITH CONVEYOR OPENINGS CLOSED

Model No.	Work Dimensions			Overall Dimensions			Flow Rate @4.2" Water Col.SCFM	Fan & Motor		Pan Volume Gallons	Fixture Quantity	Ship. Wt. Lbs.
	A	B	C	D	E	F		Dia	H.P.			
CNPB-8107	8'-0"	9'-10"	7'-6"	9'-0"	13'-2"	14'-8"	12000	27	15	335	2	4100
CNPB-10107	10'-0"	9'-10"	7'-6"	11'-0"	13'-2"	14'-8"	15000	30	15	420	2	4300
CNPB-12107	12'-0"	9'-10"	7'-6"	13'-0"	13'-2"	14'-11"	18000	33	15	500	2	5400
CNPB-14107	14'-0"	9'-10"	7'-6"	14'-0"	13'-2"	15'-4"	21000	27*	10	585	2	6600
CNPB-16107	16'-0"	9'-10"	7'-6"	17'-0"	13'-2"	15'-4"	24000	27*	15	670	2	7700
CNPB-18107	18'-0"	9'-10"	7'-6"	19'-0"	13'-2"	14'-8"	27000	30*	15	755	2	8400
CNPB-20107	20'-0"	9'-10"	7'-6"	21'-0"	13'-2"	14'-8"	30000	30*	15	840	4	9000

\*Both 18 and 20 foot booths are supplied with 2 fans.

DISTRIBUTOR:

[www.teamblowtherm.com](http://www.teamblowtherm.com) • [industrialsales@teamblowtherm.com](mailto:industrialsales@teamblowtherm.com)

**800 300 1546**

**Team Blowtherm®** Dallas, TX • Barrie, ON • Toronto, ON • Atlanta, GA • Mexico City

As we are continually trying to improve our products, specifications are subject to change without notice.

Printed in Canada  
PC-10-01-1